

INSTRUCTION MANUAL

includes Parts List

FLOW PRODUCTS

10A6100 DESIGN LEVEL B

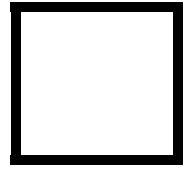

PURGEMASTER™ FLOWMETERS

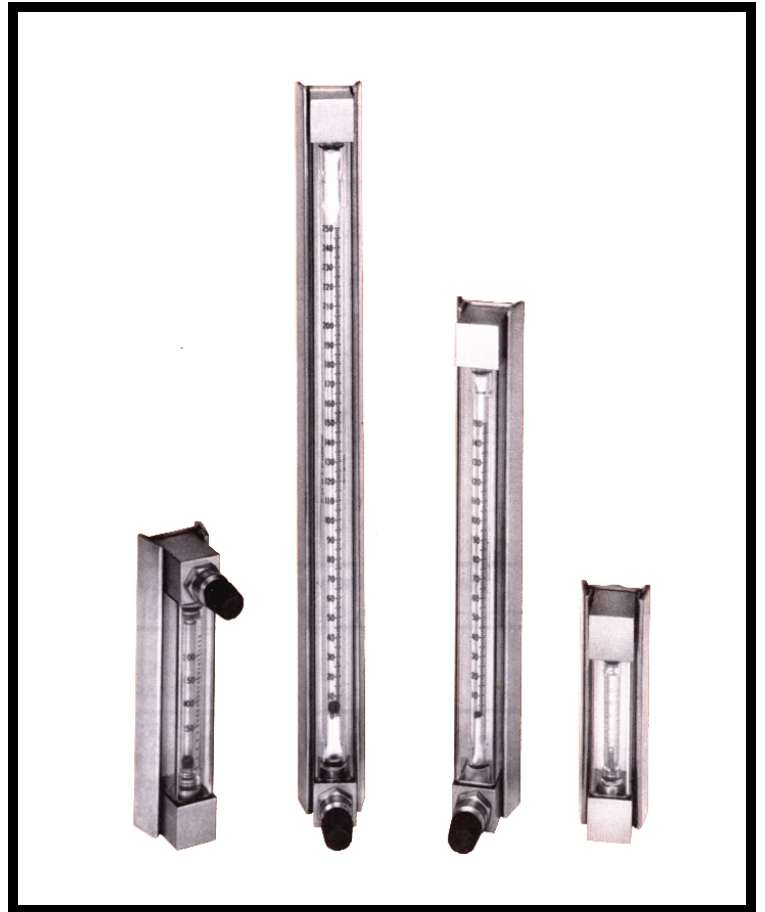

PN25104

The following are trademarks of ABB Inc:

PURGEMASTER™

The following is a registered trademark of E. I. du Pont de Nemours and Company:

VITON®

The following is a registered trademark of Atochem Incorporated:

KYNAR®

WARNING notices as used in this manual apply to hazards or unsafe practices which could result in personal injury or death.

CAUTION notices apply to hazards or unsafe practices which could result in property damage.

NOTES highlight procedures and contain information which assist the operator in understanding the information contained in this manual.

All software, including design, appearance, algorithms and source codes, is owned and copyrighted by ABB Inc. or its suppliers.

WARNING

INSTRUCTION MANUALS

Do not install, maintain or operate this equipment without reading, understanding and following the proper ABB Inc. instructions and manuals, otherwise injury or damage may result.

POSSIBLE PROCESS UPSETS

Operation & maintenance must be performed only by qualified personnel and only after securing equipment controlled by this product. Adjusting or removing this product while it is in the system may upset the process being controlled. Some process upsets may cause injury or damage.

NOTICE

The information contained in this document is subject to change without notice. ABB Inc. reserves the right to make minor changes to this publication, such as company name & logos as well as other minor corrections, without necessarily changing the publication number.

ABB Inc., its affiliates, employees, and agents, and the authors of and contributors to this publication specifically disclaim all liabilities and warranties, express and implied (including warranties of merchantability and fitness for a particular purpose), for the accuracy, currency, completeness, and/or reliability of the information contained herein and/or for the fitness for any particular use and/or for the performance of any material and/or equipment selected in whole or part with the user of/or in reliance upon information contained herein. Selection of materials and/or equipment is at the sole risk of the user of this publication.

This document contains proprietary information of ABB Inc. and is issued in strict confidence. Its use, or reproduction for use, for the reverse engineering, development or manufacture of hardware or software described herein is prohibited. No part of this document may be photocopied or reproduced without the prior written consent of ABB Inc.

Table of Contents

READ FIRST	I
1.0 INTRODUCTION	1-1
1.1 General Precautions	1-1
1.2 Description	1-3
1.3 Model Number Breakdown	1-4
1.4 Alarm Specifications	1-6
1.4.1 Ring Sensor	1-6
1.4.2 Switching Amplifier	1-6
2.0 INSTALLATION	2-1
3.0 START-UP and OPERATION	3-1
3.1 Flowmeter	3-1
3.2 Flowmeter with Alarms	3-1
4.0 MAINTENANCE	4-1
4.1 General	4-1
4.2 Meter Disassembly	4-2
4.3 Removing the Control Valve	4-2
5.0 PARTS LISTS	5-1
5.1 Basic Meter Parts	5-1
5.2 Alarm Parts	5-4
5.3 Parts For Assembly Of Series 53R-2100 Regulator To Purgemaster Meter	5-5
5.4 Model 10A6130 Flush Panel Mounting Purgemaster	5-7

Figure List

FIGURE 2-1. METER OUTLINE AND MOUNTING DIMENSIONS.....	2-2
FIGURE 2-2. OUTLINE DIMENSIONS FOR PANEL MOUNTED OR IN-LINE METER WITH REGULATOR.....	2-3
FIGURE 2-3. OUTLINE DIMENSIONS FOR WALL MOUNTED METER WITH REGULATOR	2-4
FIGURE 2-4. METER WITH ALARM.....	2-5
FIGURE 2-5. OUTLINE & MOUNTING DIMENSIONS FOR REAR-MOUNTED METER.....	2-6
FIGURE 2-6. OUTLINE DIMENSIONS OF PIPING & DIFFERENTIAL PRESSURE REGULATOR FOR REAR-MOUNTED PURGEMASTER METER.....	2-7
FIGURE 2-7. ALARM SWITCHING AMPLIFIER.....	2-8
FIGURE 2-8. TRANSFORMER ISOLATED BARRIER INTERCONNECTION DIAGRAM	2-9
FIGURE 4-1. VALVE STEM ASSEMBLY FOR KYNAR END FITTING	4-3
FIGURE 5-1. BASIC METER PARTS	5-3
FIGURE 5-2. ALARM PARTS	5-5
FIGURE 5-3. WALL MOUNTING PROCEDURE.....	5-5
FIGURE 5-4. INLINE & PANEL MOUNTING PROCEDURE.....	5-5
FIGURE 5-5. MODEL 6130 FLUSH PANEL MOUNT PARTS	5-7

Table List

TABLE 5-1. BASIC METER PARTS	5-2
TABLE 5-2. ALARM PARTS.....	5-4
TABLE 5-3. ALARM SWITCHING AMPLIFIER	5-4
TABLE 5-4. BASIC REGULATOR	5-6
TABLE 5-5. BRACKETS & SCREWS FOR WALL MOUNTING	5-6
TABLE 5-6. PIPING KITS FOR IN-LINE OR PANEL-MOUNTED METER UNITS	5-6
TABLE 5-7. PIPING KITS FOR WALL-MOUNTED REGULATOR UNITS.....	5-6
TABLE 5-8. MODEL 10A6130 FLUSH PANEL MOUNT PARTS LIST.....	5-8

READ FIRST

WARNING

INSTRUCTION MANUALS

Do not install, maintain, or operate this equipment without reading, understanding and following the proper factory-supplied instructions and manuals, otherwise injury or damage may result.

RETURN OF EQUIPMENT

All Flowmeters and/or Signal Converters being returned to the factory for repair must be free of any hazardous materials (acids, alkalis, solvents, etc). A Material Safety Data Sheet (MSDS) for all process liquids must accompany returned equipment. Contact the factory for authorization prior to returning equipment.

**Read these instructions before starting installation;
save these instructions for future reference.**

Contacting the Factory . . .

Should assistance be required with any of the company's products, contact the following:

Telephone:

**24-Hour Call Center
1-800-HELP-365**

E-Mail:

ins.techsupport@us.abb.com

Internet:

www.abb.com

- Select Instrumentation & Analytical from the Our Offerings section
- Select your country from the Contact Us drop-down menu on the right-side of the page and complete the requested information.

1.0 INTRODUCTION

1.1 General Precautions

⚠ The ABB Automation Series 10A6100 PURGEMASTER™ Flowmeters have been designed to operate up to maximum design working pressures and temperatures as shown in the following chart.

MAXIMUM FLUID PRESSURE (PSIG)					
END FITTING/ADAPTER MATERIAL					
316 SST/316 SST		316 SST/KYNAR		KYNAR/KYNAR	
FLUID TEMPERATURE		FLUID TEMPERATURE		FLUID TEMPERATURE	
MAX. 250° F	DESIGN 100° F	MAX. 200° F	DESIGN 100° F	MAX. 150° F	DESIGN 100° F
250 psig	250 psig	200 psig	250 psig	150 psig	200 psig

Minimum Fluid Temperature:

32° F (0° C).

Ambient Temperature:

32° F (0° C) to 140° F (60° C).

Purgemaster with Differential Pressure Regulator:

Design Pressure: 200 psig at 100° F (38° C)

Maximum Operating pressure: 200 psig at 200° F (93° C)

This is not a certification that the glass tubes will not break at pressures less than those listed above. Inherent material limitations can result in tube breakage due to conditions beyond our control. For example: glass is a brittle material which may break upon impact; glass if subjected to thermal shock may break; glass is notch sensitive in that scratches, nicks or cracks may result in breakage when pressurized; faulty installation or operating methods can cause tube breakage regardless of operating pressure.

Glass meter tubes are not recommended for either hot or strong alkalies, fluorine, hydrofluoric acid, steam or water over 200° F (93° C). Glass meter tubes should be periodically inspected for signs of wear. With certain fluids the glass may erode evenly so wear is not visible. If wear is suspected, the tube must be replaced.

It is important that the meter construction be compatible with the process to which the meter is applied. It is especially important that the O-ring material be compatible with the process fluid. The glass meter tube can break if the improper materials are used.

For example: VITON® O-rings must never be used for ammonia service; the corrosive attack of ammonia on VITON is extreme, and could cause a VITON O-ring to swell and break the glass metering tube.

The meter should be mounted or supported to minimize vibration.

The use of a pressure relief valve and/or a rupture disc is recommended in the pipeline containing the flowmeter. The device should be located so as to prevent glass meter tube breakage in the event of an over pressurization of the line.

Avoid the use of quick acting devices in the fluid stream since they can cause shock waves which may damage the meter.

When applied to a high pressure gas cylinder, at least two stepdown pressure regulators are to be used between the flowmeter and the cylinder.

Fully relieve pressure from the flowmeter before attempting to remove the meter tube.

Make sure the fasteners that lock the meter end fittings in place are secure. The fasteners must be checked before the flowmeter is put into service or when it is returned to service after maintenance. Loose end fittings may result in glass meter tube breakage.

The glass meter tube must be periodically inspected and replaced if cracked, nicked, scratched or worn.

Operator protection shields which have been damaged or show any signs of degradation must be replaced.

It is recommended that the piping system be checked for leaks prior to start-up.

WARNING
DO NOT OPERATE THE FLOWMETER WITHOUT THE OPERATOR
PROTECTION SHIELD IN PLACE. TO DO SO MAY RESULT IN
OPERATOR INJURY.

1.2 Description

The ABB Automation Series 10A6100 PURGEMASTER meter is a low capacity, glass tube type, variable area meter used to measure and visually indicate the flow rates of liquids and gases.

The meters are available in 1-1/2, 3, 5 and 10 inch scale lengths. The 1-1/2 and 3 inch meters use plain taper tubes; the 5 and 10 inch meters use guided tubes (tri-flat and beaded). The meter tube may have either a 1/16, 1/8, 5/32 or 1/4 inch inlet bore along with the appropriate ball float for the capacity and fluid being measured. The 1-1/2 inch meter tube scale is only offered in percent of maximum flow. The scale on the 3 inch meter tube may be calibrated for direct reading for air and water flow or for percent of maximum flow. The 5 and 10 inch meters have either direct reading scales for air and water or a millimeter scale. For the millimeter scale, a calibration curve is furnished so the position of the ball float, as read in millimeters, can be converted to flow rate values.

The body of the PURGEMASTER meter is stainless steel. The inlet and outlet end fittings, which can be stainless steel or KYNAR[®], are inserted into holes in the body and are held in place with a retainer clip or nut. These end fittings contain the tube adapters that hold the meter tube and float. The tube is installed from the front of the meter without disassembling the meter or removing the process connections. An operator protection shield snaps into position over the tube and is held in place by the meter body.

PURGEMASTER meters are available with either a control valve located in the inlet end fitting or in the outlet end fitting, or with no control valve. For models with the control valve in the inlet end fitting or with no control valve, an internal back check is installed in the outlet end fitting. For models with the control valve in the outlet end fitting, no back check is provided.

1.3 Model Number Breakdown

Refer to the ABB Automation manufacturing specification sheet or to the instrument nameplate to determine the specific model number of the instrument furnished. Standard instrument options may be identified from the following breakdown.

PURGEMASTER Flowmeter	<u>10A61</u>								
Process Connection									
1/4" NPT	3								
Specials	Z								
Meter Tube, Scale Length									
3" scale	1								
5" scale	2								
10" scale	3								
1-1/2"scale	4								
Valve Location (Note 1)									
Without Valve									A
Outlet Valve, Std. Capacity									M
Inlet Valve, Std. Capacity									N
Outlet Valve, Low Capacity									C
Inlet Valve, Low Capacity									D
Outlet Valve, High Capacity									E
Inlet Valve, High Capacity									F
Design Level									B
Tube Size									
1/8"	1								
1/4"	2								
1/16" (Only w/ 1-1/2" and 5" length) (Requires low capacity valve)	3								
5/32" (Only w/1-1/2" length)	4								
Materials of Construction									
Fittings/O-Rings/Adaptors									
316ss/Viton/SS									B
*Kynar/Viton/Kynar (NPT only)									D
316ss/Buna/SS									E
*Kynar/Buna/Kynar (NPT only)									G
316SS/Viton/Kynar									H
316SS/Buna/Kynar									J
*316SS/EPR/SS									L
Special									Z
<i>*Not available with Regulator</i>									
Mounting (Meter & Regulator)									
In-Line (Pipe)	1								
Wall Mount	2								
Rear Panel Mount	3								
Front Panel Mount	4								
Regulator Piping									
No Regulator									X
Stainless Steel									A

1.3 Model Number Breakdown (continued)

PURGEMASTER Flowmeter	10A61	---	---	---	---	---	---	---	---
		A	A	E					
Alarm Option* (Includes Ring Sensor)									
(Not available with 1-1/2" size. 1/8 and 1/4" diameter tube only)									
Not Required	00								
Minimum Alarm	10								
Maximum Alarm	20								
Minimum & Maximum Alarm (5 & 10" Tubes Only) ...	30								
Modified for Alarms without Sensor or Relay	90								
*Must use Metallic Floats, SS, Ca									
Connection Accessories									
Not Required		A	A						
ABB Logo Tag			A						
Language									
English				E					
Alarm Relay (Power Requirements)									
Not Required					X				
110 Vac					3				
220 Vac					4				
External Metal Scale (Rear Panel Mount. 5 & 10" Only)									
Not Required						B			
Required						C			
Calibration									
Standard Accuracy ($\pm 10\%$, 1-1/2 & 3" scale $\pm 2\%$, 5 & 10" scale)									
Except 1/16-G5 Tubes, 1/8-038-G6 & 1/8-041-G6 are $\pm 5\%$)							1		
Calibrated Accuracy ($\pm 4\%$, 1-1/2 and 3" Scale)							2		
Calibrated Accuracy ($\pm 1\%$, 5 & 10" Scale Except 1/16-G5 tubes, 1/8-038-G6 & 1/8-041-G6 are $\pm 2\%$)							3		
Scales									
Not Required								X	
Direct Reading (Standard Scales listed in Spec Sheet)								B	
Direct Reading (Special Scales)								C	
Millimeter								D	
Percent								E	
Dt/Df								F	
Standard Ranges									
2.5 scfh Air @ 10psig & 70°F (3" Only)									3XA
2.0 scfm Air @ 14.7psia & 70°F (3" Only)									3XE
240 cc/min Water (3" Only)									3AD
Other (Supply 3 Digit Code or leave blank for factory sizing)									XXX

Notes:
 1. Specials, low and high capacity valves are not available in KYNAR.

1.4 Alarm Specifications

1.4.1 Ring Sensor

Pepperl & Fuchs RC-10-14-N3 for 1/8 inch meter tubes, RC-15-14-N3 for 1/4 inch meter tubes Bistable Switching Action - Namur output

Sensor	RC-10-14-N for 1/8 inch meter tubes RC-10-15-N for 1/4 inch meter tubes Bistable Switching Action
FM Approved for:	Class I, Div 1, Groups A, B, C and D; Class II, Div 1, Groups E, F, and G Class III, Div 1
Power supply requirements:	5 to 25 V dc
Load Current (current range):	$\leq 0.01\text{mA}$ $\geq 0.3 \text{ mA}$
Repeatability:	$\leq 0.01 \text{ mm}$
Self Inductance:	100 μH
Self Capacitance:	150 nF
Ambient temp. limit:	-14°F(-26° C) to 158°F(70°C)
Cable:	6 1/2 feet (2m) standard (max. 9800 feet) (3000 m) possible)
Housing:	Crastin, black
Protective Class:	NEMA 4X/IP67
Weight:	150 g (approximate)

1.4.2 Switching Amplifier

This device is a single-channel, transformer-isolated intrinsic safety barrier with a built-in amplifier which isolates and transfers discrete signals (NAMUR sensors/mechanical contacts) from a hazardous area to a safe area.

It may also be used to act as an amplifier/interface for discrete signals in non-explosive applications.

The output changes state when the input signal changes state depending on the mode of operation selected.

Type:	Pepperl + Fuchs KFA5-SR2-Ex1. W - 110 Vac Single Alarm KFA6-SR2-Ex1. W - 220 Vac Single Alarm KFA5-SR2-Ex2. W - 110 Vac Dual Alarm KFA6-SR2-Ex2. W - 220 Vac Dual Alarm
Contact rating:	max. 250 VA, max. 2A
Supply Voltage:	120 Vac, 240 Vac, $\pm 15\%$, 45 - 65 Hz
Response Time:	Energize approximately 20 ms, De-energized approximately 20 ms
Output Type:	Single Pole Double Throw (SPDT)
Ambient temp. limits:	-4°F (-20°C) to + 140°F (60°C)
Maximum Wire Size:	2.5 mm ² (14 AWG)
Approvals:	IP20; Hazardous field circuit EExia IIC and FM Class I, Div. 1, Groups A to G. The KFA relay amplifiers must be installed in the non-hazardous area when connected to the RC-10 sensors.
Housing Material:	Makrolon
Weight:	150 g. (5.2 oz.)

2.0 INSTALLATION

WARNING
DO NOT OPERATE THE FLOWMETER WITHOUT THE OPERATOR PROTECTION SHIELD IN PLACE. TO DO SO MAY RESULT IN OPERATOR INJURY.

The meter may be mounted directly in the pipeline or on the surface of a wall or panel. Whenever making piping connections, support the meter end fittings with a 7/8 inch open-end wrench to prevent damage to the meter assembly.

To mount the meter with or without an in-line differential pressure regulator to the surface of a panel, perform the following procedure:

1. Remove the tube by performing the steps presented in the Maintenance Section 4 of this manual.
2. Remove the white backing from the meter body. To do this slide the backing to one side and insert a small screwdriver (or similar tool) under the exposed edge to pry the backing up and out.
3. The meter body has two countersunk holes for mounting the meter with #8 flat head screws. Holes must be provided in the panel for piping connections to the meter fittings. Refer to Figures 2-1 and 2-2 for the outline and mounting dimensions for panel mounted meters.
4. The meter body can now be fastened to the panel and the white backing, tube, and operator safety shield can be replaced.

Refer to Figure 2-3 for outline and mounting dimensions for wall-mounted meters with a differential pressure regulator.

If the alarm option is supplied with the meter, refer to Figures 2-4, 2-5 and 2-6, and Sub-Section 3.2.

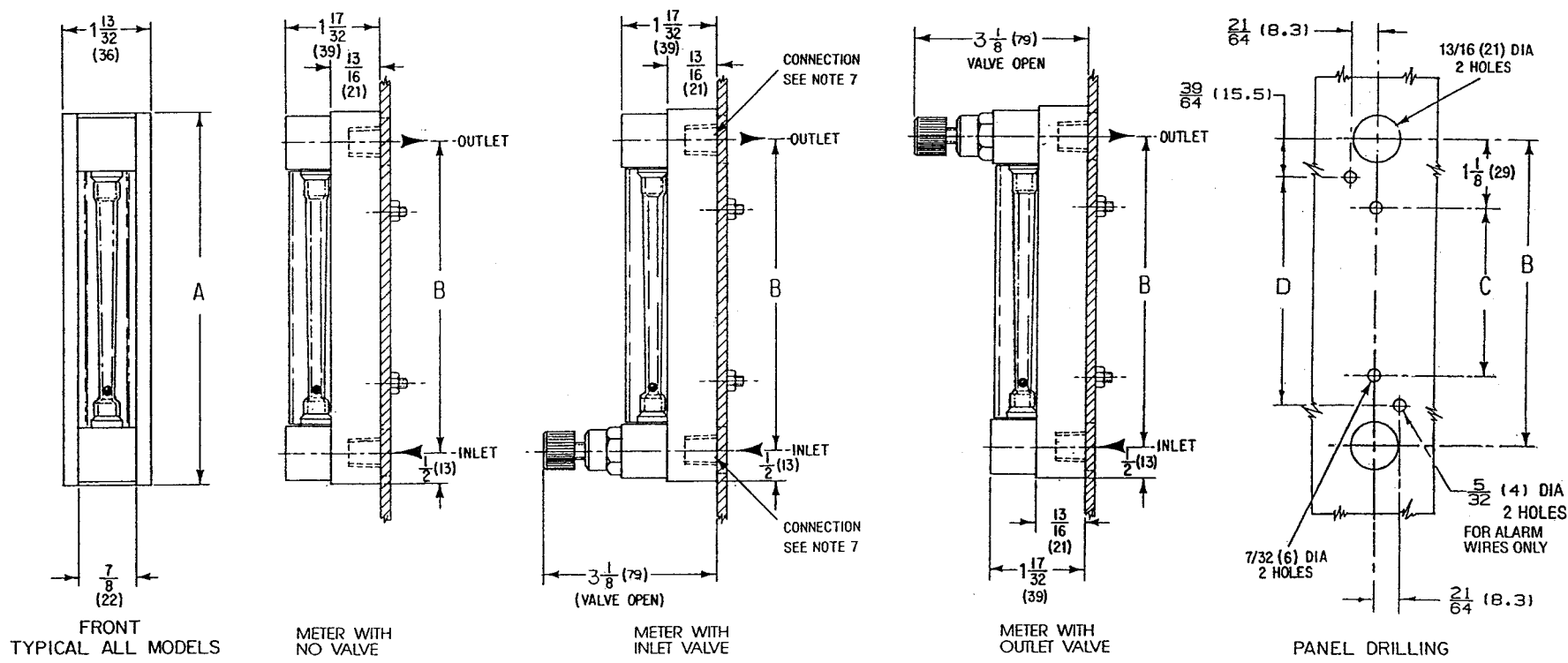

NOM SCALE LENGTH		A		B		C		D	
INCH	mm	INCH	mm	INCH	mm	INCH	mm	INCH	mm
1 1/2	38	4 3/4	121	3 23/32	94	1 15/32	37	—	—
3	76	5 15/16	151	4 15/16	125	2 1/16	68	3 23/32	94
5	127	10 3/8	264	9 3/8	238	7 1/8	181	8 5/32	207
10	254	14 13/16	376	13 13/16	351	11 9/16	294	12 19/32	320

NOTES:

1. DIMENSIONS ARE IN INCHES, UNLESS OTHERWISE SPECIFIED.
2. DIMENSIONS IN PARENTHESES () ARE IN MILLIMETERS.
3. ALL DIMENSIONS SUBJECT TO MANUFACTURING TOLERANCE OF ±1/8 INCH (3mm), UNLESS OTHERWISE SPECIFIED.
4. DIMENSIONS GUARANTEED ONLY IF THIS PRINT IS CERTIFIED.
5. TO PANEL MOUNT METER, WHITE BACKGROUND MUST BE REMOVED TO GAIN ACCESS TO HOLES IN BACKPLATE. USE #8 FLAT HEAD SCREWS.
6. THIS DRAWING IS THIRD ANGLE PROJECTION AS SHOWN:
7. CONNECTIONS ARE AVAILABLE IN 1/4 NPT

OD-10-2711 R3

FIGURE 2-1. METER OUTLINE AND MOUNTING DIMENSIONS

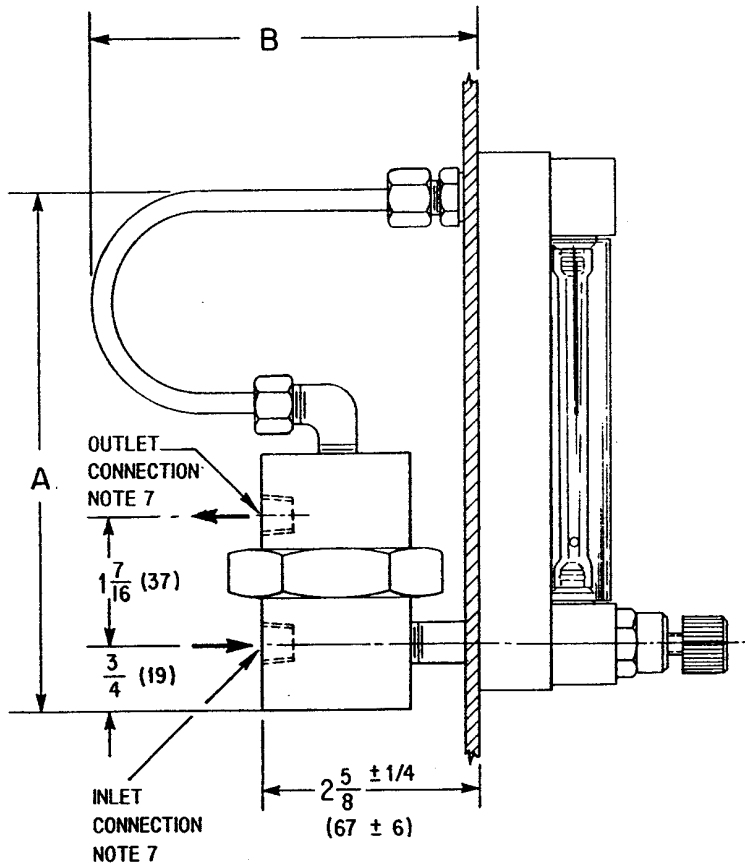

NOTES:

1. DIMENSIONS ARE IN INCHES, UNLESS OTHERWISE SPECIFIED.
2. DIMENSIONS IN PARENTHESES () ARE IN MILLIMETERS.
3. ALL DIMENSIONS ARE SUBJECT TO A MANUFACTURING TOLERANCE OF $\pm 1/8$ INCH (3 mm), UNLESS OTHERWISE SPECIFIED.
4. DIMENSIONS GUARANTEED ONLY IF THIS PRINT IS CERTIFIED.
5. FOR OUTLINE DIMENSIONS OF METER AND PANEL DRILLING DIMENSIONS SEE OD-10-2711 OR OD-10-2750
6. TO PANEL MOUNT A FACTORY ASSEMBLED METER WITH REGULATOR THE TUBING AND REGULATOR MUST BE REMOVED.
7. CONNECTIONS ARE AVAILABLE IN 1/4 NPT

NOM SCALE LENGTH		A		B	
INCH	mm	INCH	mm	INCH	mm
1 1/2	38	5 7/8	149	4 3/8 $\pm 1/4$	111 ± 6
3	76	5 7/8	149	4 3/8 $\pm 1/4$	111 ± 6
5	127	10 1/4	260	2 25/32 $\pm 1/4$	71 ± 6
10	254	14 11/16	373	2 25/32 $\pm 1/4$	71 ± 6

FIGURE 2-2. OUTLINE DIMENSIONS FOR PANEL MOUNTED OR IN-LINE METER WITH REGULATOR

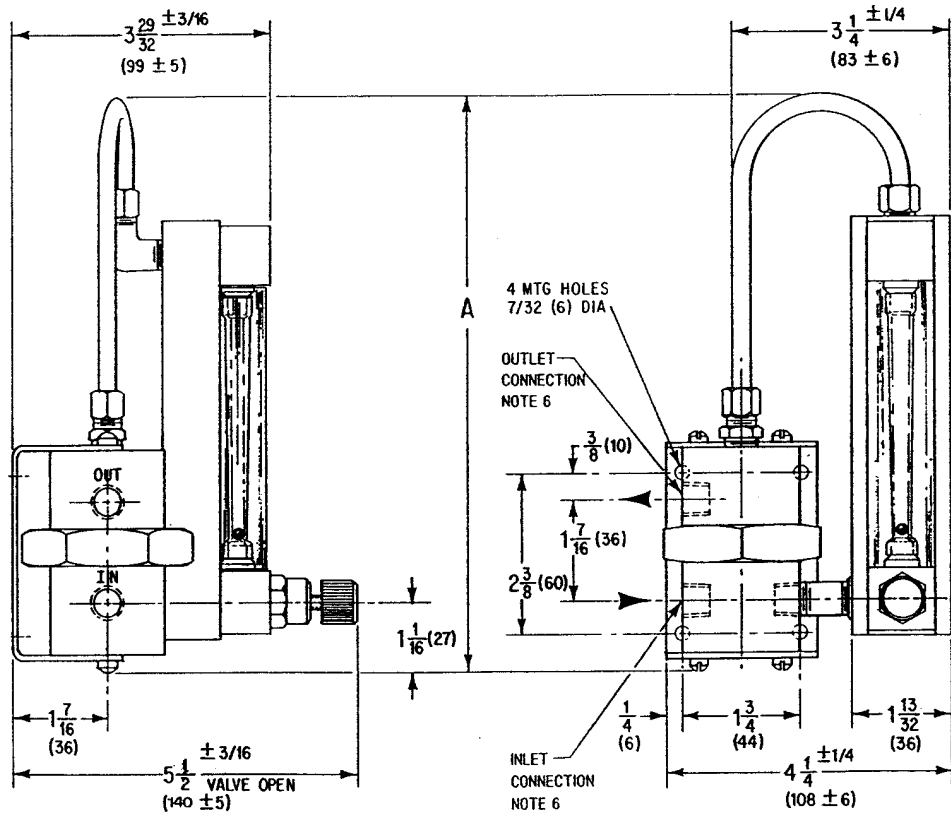

NOM SCALE LENGTH		A	
INCH	mm	INCH	mm
1 1/2	38	7 1/2	190
3	76	8 7/8	225
5	127	13 5/16	338
10	254	17 3/4	451

NOTES:

1. DIMENSIONS ARE IN INCHES, UNLESS OTHERWISE SPECIFIED.
2. DIMENSIONS IN PARENTHESES () ARE IN MILLIMETERS.
3. ALL DIMENSIONS SUBJECT TO A MANUFACTURING TOLERANCE OF ± 1/8 INCH (3 mm), UNLESS OTHERWISE SPECIFIED.
4. DIMENSIONS GUARANTEED ONLY IF THIS PRINT IS CERTIFIED.
5. FOR OUTLINE DIMENSIONS OF METER, SEE DWG NO. C-OD-10-2711 & OD-10-2750
6. CONNECTIONS ARE AVAILABLE IN 1/4 NPT

OD-10-2713 R3

FIGURE 2-3. OUTLINE DIMENSIONS FOR WALL MOUNTED METER WITH REGULATOR

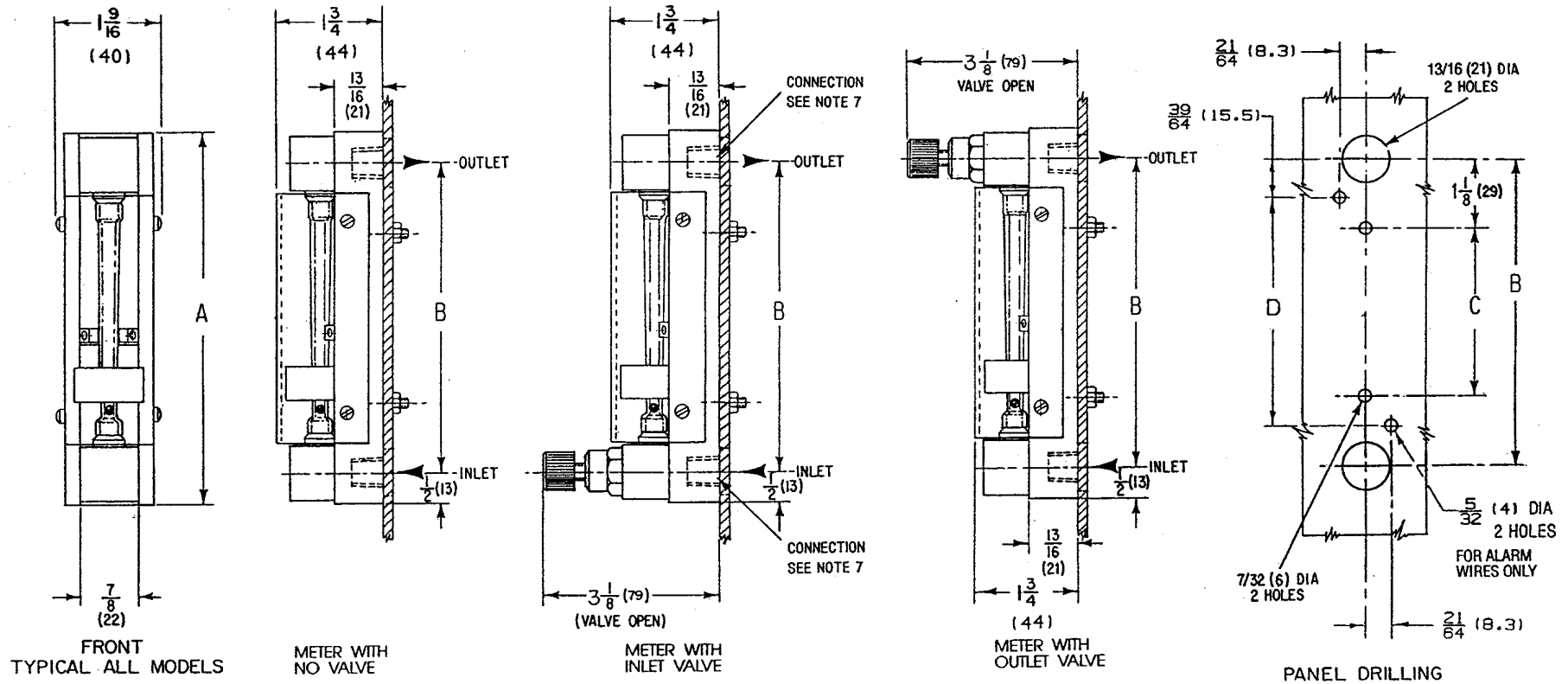

NOM SCALE LENGTH		A		B		C		D	
INCH	mm	INCH	mm	INCH	mm	INCH	mm	INCH	mm
3	76	5 $\frac{15}{16}$	151	4 $\frac{15}{16}$	125	2 $\frac{11}{16}$	68	3 $\frac{23}{32}$	94
5	127	10 $\frac{3}{8}$	264	9 $\frac{3}{8}$	238	7 $\frac{1}{8}$	181	8 $\frac{5}{32}$	207
10	254	14 $\frac{13}{16}$	376	13 $\frac{13}{16}$	351	11 $\frac{9}{16}$	294	12 $\frac{19}{32}$	320

NOTES:

1. DIMENSIONS ARE IN INCHES, UNLESS OTHERWISE SPECIFIED.
2. DIMENSIONS IN PARENTHESES () ARE IN MILLIMETERS.
3. ALL DIMENSIONS SUBJECT TO MANUFACTURING TOLERANCE OF $\pm 1/8$ INCH (3mm), UNLESS OTHERWISE SPECIFIED.
4. DIMENSIONS GUARANTEED ONLY IF THIS PRINT IS CERTIFIED.
5. TO PANEL MOUNT METER, WHITE BACKGROUND MUST BE REMOVED TO GAIN ACCESS TO HOLES IN BACKPLATE. USE #8 FLAT HEAD SCREWS.
6. THIS DRAWING IS THIRD ANGLE PROJECTION AS SHOWN:
7. CONNECTIONS ARE AVAILABLE IN 1/4 NPT

OD-10-2750 R0

FIGURE 2-4. METER WITH ALARM

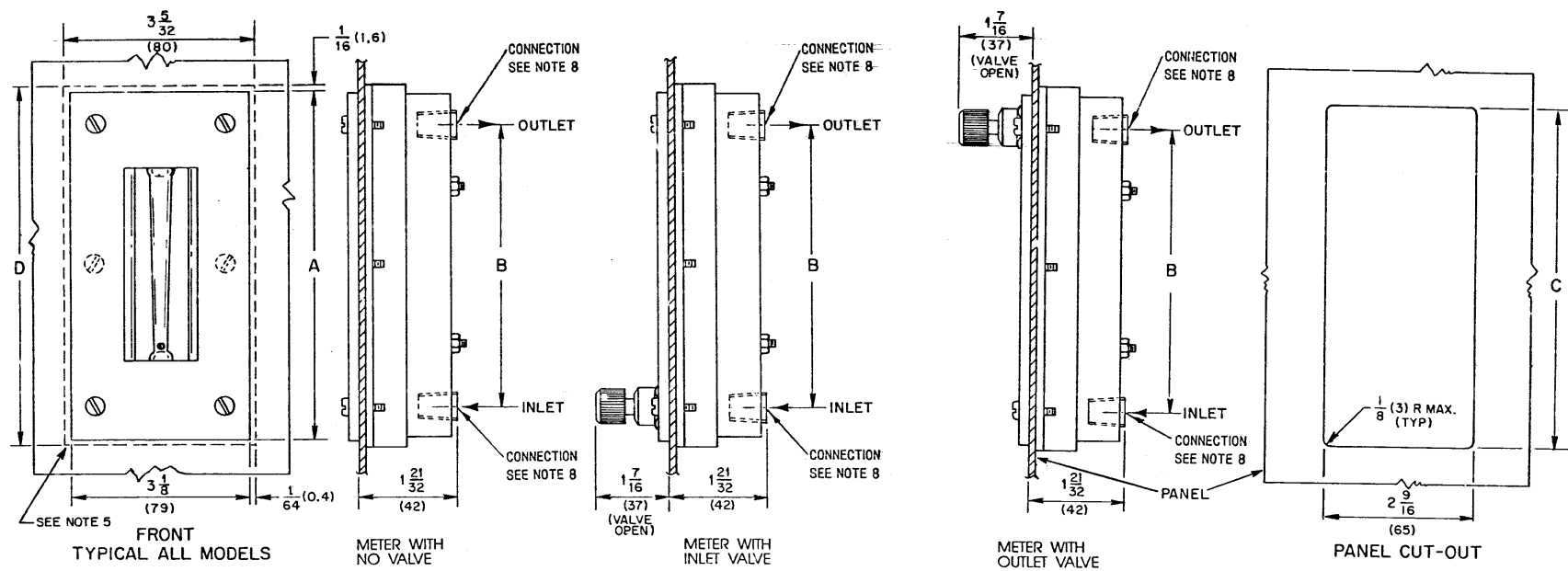

NOM SCALE LENGTH		A		B		C		D	
INCH	mm	INCH	mm	INCH	mm	INCH	mm	INCH	mm
1 1/2	38	4 31/32	126	3 23/32	94	4 27/32	123	5 3/32	129
3	76	6 3/16	157	4 15/16	125	6 1/16	154	6 5/16	160
5	127	10 5/8	270	9 3/8	238	10 1/2	267	10 3/4	273
10	254	15 1/16	383	13 13/16	351	14 15/16	379	15 3/16	386

- NOTES:
1. DIMENSIONS ARE IN INCHES, UNLESS OTHERWISE SPECIFIED.
 2. DIMENSIONS IN PARENTHESES () ARE IN MILLIMETERS.
 3. ALL DIMENSIONS SUBJECT TO MANUFACTURING TOLERANCE OF ±1/8 INCH (3mm), UNLESS OTHERWISE SPECIFIED.
 4. DIMENSIONS GUARANTEED ONLY IF THIS PRINT IS CERTIFIED.
 5. DOTTED LINE INDICATES REAR OF PANEL CLEARANCE REQUIREMENTS.
 6. PANEL HARDWARE FOR MAX 5/16" PANEL.
 7. THIS DRAWING IS THIRD ANGLE PROJECTION AS SHOWN:
 8. CONNECTIONS ARE AVAILABLE IN 1/4 NPT

Ref. OD-10-2715, r.2

FIGURE 2-5. OUTLINE & MOUNTING DIMENSIONS FOR REAR-MOUNTED PURGEMASTER METER

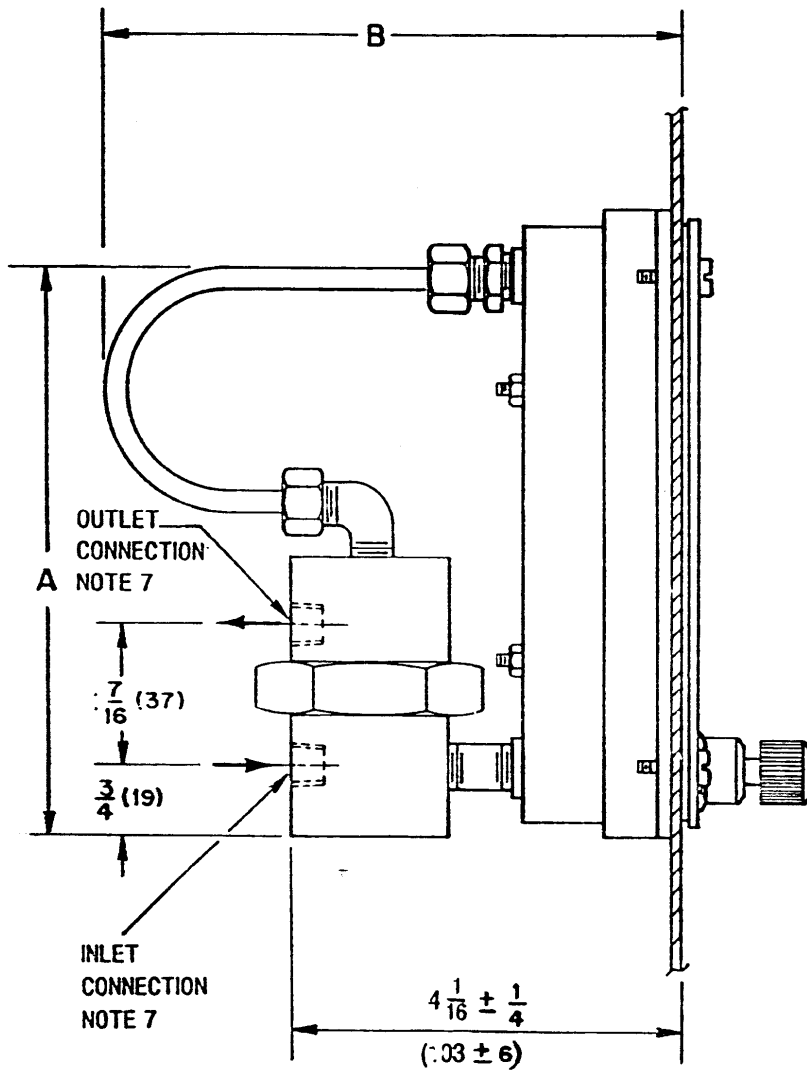

NOTES:

1. DIMENSIONS ARE IN INCHES, UNLESS OTHERWISE SPECIFIED.
2. DIMENSIONS IN PARENTHESES () ARE IN MILLIMETERS.
3. ALL DIMENSIONS ARE SUBJECT TO A MANUFACTURING TOLERANCE OF $\pm 1/8$ INCH (3 mm), UNLESS OTHERWISE SPECIFIED.
4. DIMENSIONS GUARANTEED ONLY IF THIS PRINT IS CERTIFIED.
5. FOR OUTLINE DIMENSIONS OF METER AND PANEL CUT-OUT DIMENSIONS SEE OD-10-2715.
6. PANEL HARDWARE FOR MAX $\frac{5}{16}$ PANEL.
7. CONNECTIONS ARE AVAILABLE IN 1/4 NPT

SCALE LENGTH	A	B
$1 \frac{1}{2}$ (38)	$5 \frac{7}{8}$ (149)	$5 \frac{7}{8} \pm \frac{1}{4}$ (149 ± 6)
3 (76)	$5 \frac{7}{8}$ (149)	$5 \frac{7}{8} \pm \frac{1}{4}$ (149 ± 6)
5 (127)	$10 \frac{1}{4}$ (260)	$4 \frac{21}{32} \pm \frac{1}{4}$ (118 ± 6)
10 (254)	$14 \frac{11}{16}$ (373)	$4 \frac{21}{32} \pm \frac{1}{4}$ (118 ± 6)

FIGURE 2-6. OUTLINE DIMENSIONS OF PIPING & DIFFERENTIAL PRESSURE REGULATOR FOR REAR-MOUNTED PURGEMASTER METER

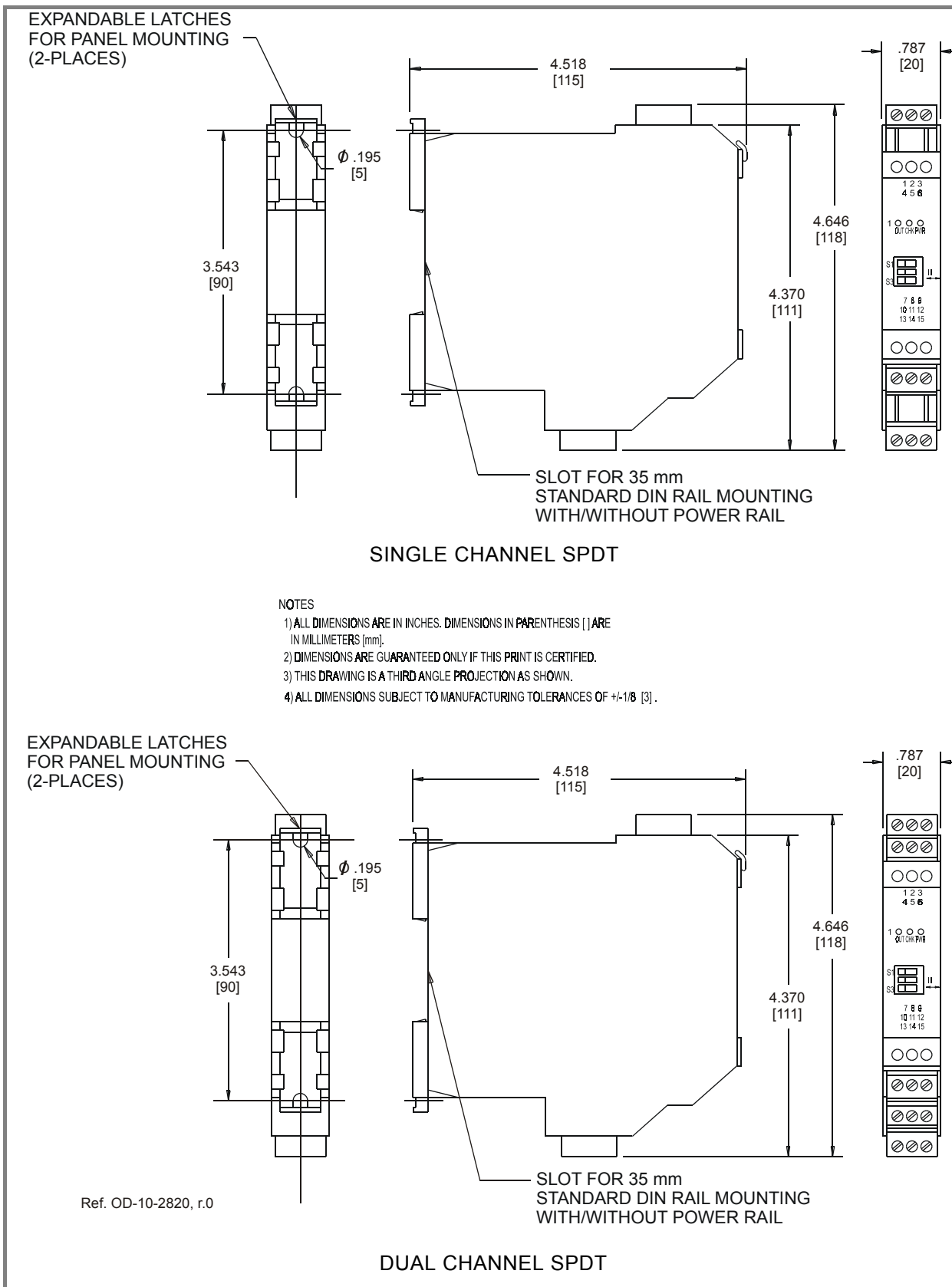

FIGURE 2-7. ALARM SWITCHING AMPLIFIER

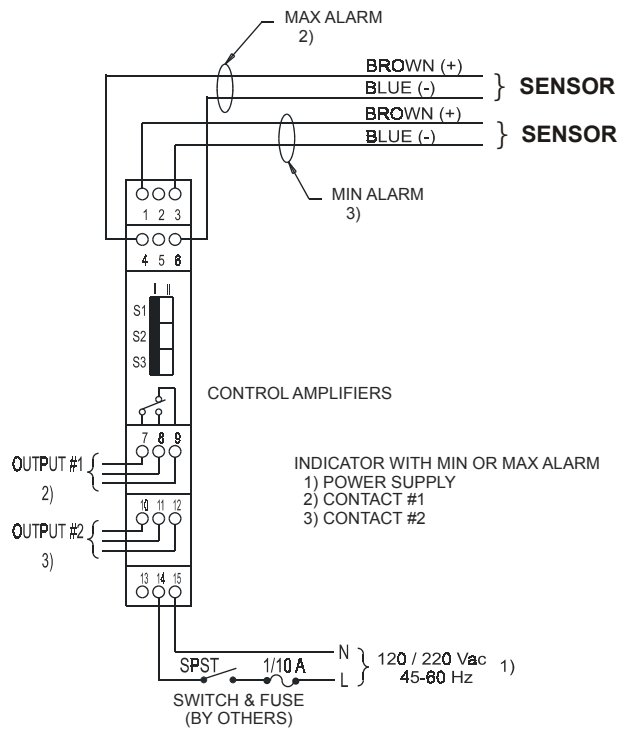
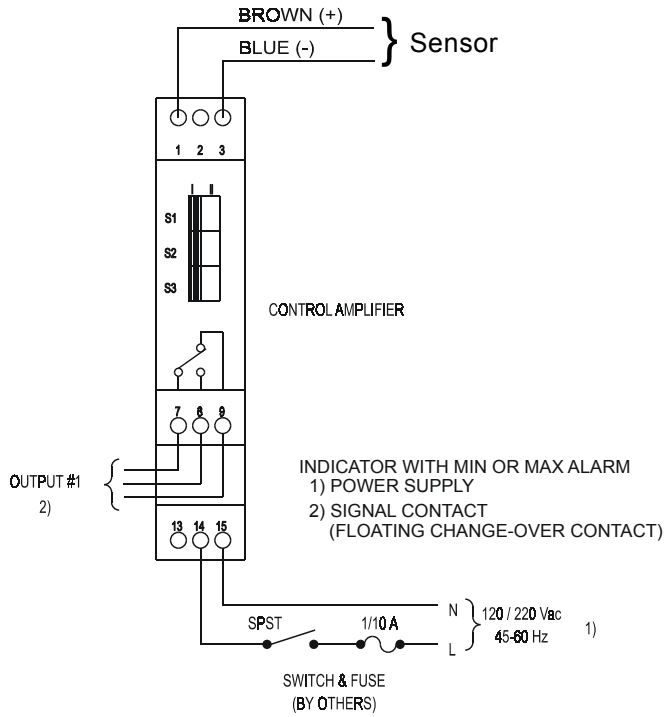

FIGURE 2-8. TRANSFORMER ISOLATED BARRIER INTERCONNECTION DIAGRAM

3.0 START-UP and OPERATION

3.1 Flowmeter

Start flow through the meter slowly to avoid violent movement of the float that could damage the meter parts. Flow rate is determined by reading the tube scale at the point corresponding to the horizontal center line of the ball float.

3.2 Flowmeter with Alarms

Purgemaster meters can be supplied with alarms for 1/8 and 1/4 inch tubes in 3, 5 and 10 inch scale lengths. Metallic ball floats must be used in all meters with alarms. Due to the shorter metering tube, 3 inch scale length meters are only available with single alarms (minimum or maximum). Single and dual alarms are available in 5 and 10 inch scale length meters.

The alarm consists of a ring sensor (that encircles the meter tube) and a remote mounted switching amplifier. The sensor with a bistable switching action uses the position of the ball float as the input signal for actuation. The sensor is adjustable over the metering range of the tube. The sensor can be adjusted using a 1.5 mm hex socket wrench to loosen the locking screws and sliding the sensor up or down on the meter tube (refer to Figures 2-4 and 5-2). Re-tighten the locking screws.

WARNING

Remove all pressure from the meter before removing the operator protection shield to adjust the sensors. Replace the operator protection shield before placing the meter back into service.

The alarm sensors are suitable for hazardous locations because the sensors are intrinsically safe when used with the switching amplifier. However, the amplifier is only suitable for non-hazardous locations. Wiring between sensors and amplifier shall be in accordance with ANSI/ISA RP12.6 Installation Of Intrinsically Safe Systems For Hazardous (Classified) Locations.

Refer to Sub Section 1.4 for alarm specifications

4.0 MAINTENANCE

4.1 General

The only maintenance required is the occasional cleaning of the tube, float and operator protection shield. The meter should be cleaned frequently enough to assure accuracy and float visibility. To clean the tube and float proceed as follows:

1. Shut off fluid flow to the meter. Then drain and/or purge if possible. **BE ABSOLUTELY SURE ALL PRESSURE HAS BEEN RELIEVED.**
2. Starting at either end of the meter, squeeze one side of the shield inward to disengage the shield retaining lip. Continue to squeeze one side inward while advancing along the length of the shield using a forward rolling motion to remove the shield from the body.
3. Remove the glass tube by grasping it at mid-point and pushing up against the compression of the spring load (or down if a valve is on the outlet) and pulling it out.
4. With a pair of tweezers, pull the float stop out from the outlet end of the tube. Then, with one hand over the outlet end, invert the tube to catch the ball float. The tube and float are precision manufactured parts and as such should never be subjected to unnecessary shock or strains either mechanically or through extreme temperature change. Handle the float with care as a nick or scratch may affect meter accuracy.
5. Clean the tube and float with a mild detergent and water, or a suitable solvent. Use a soft cloth or tube brush to clean the meter tube.
6. Clean the shield with a solution of detergent and water. If this does not clean the shield sufficiently, use kerosene and follow up with detergent and water. Rinse with clean water and dry with a soft cloth.

Reassembly is accomplished by following the above procedure in reverse.

CAUTION

Do not clean the protective shield with cleaners containing strong mineral acids or organic solvents such as ketones, chlorinated hydrocarbons or aromatics. Using such cleaners may impair the protective and optical qualities of the shield.

4.2 Meter Disassembly

Refer to Figure 5-1

1. To remove either end fitting from the meter body after the tube and float are removed proceed as appropriate:

For stainless steel end fittings, use a screwdriver to pry the retainer out of the locking groove at the back of the body.

For KYNAR end fittings, loosen and remove the nut that screws onto the end fitting from the back of the body. Remove the appropriate end fitting from the body.

2. To replace the adapter O-rings, first remove the retainer spring by using a thin, pointed tool to pry one end of the spring inward and upward simultaneously. With the retainer spring removed, the adapter can be lifted from the fitting and the O-rings can be removed and replaced. Do not use any tool that will damage the O-ring seal areas. Replacement O-rings should be lightly lubricated with silicone grease.

3. Reassemble the adapters into the end fittings as appropriate. Install the retainer spring by inserting one end in the groove in the end fitting and progressively working around the perimeter of the spring with a small flat blade screwdriver. **IT IS IMPORTANT THAT THE RETAINER SPRING IS FIRMLY SEATED IN THE GROOVE TO SECURELY RETAIN THE ADAPTER IN THE END FITTING.**

4. To reassemble the end fittings into the body, make sure that the tube adapter in each end fitting is facing the other and install each end fitting as appropriate.

4.3 Removing the Control Valve

To remove the control valve from the end fitting for cleaning purposes without removing the tube, operator shield, or end fitting, perform the following procedure. Fluid flow in the meter must first be shut off, the meter must be drained or purged, and **ANY RESIDUAL PRESSURE IN THE METER MUST BE RELIEVED BEFORE PROCEEDING.**

a. While supporting the end fitting with a 7/8 inch open end wrench, loosen the valve bonnet nut on the valve stem with an 11/16 inch box end or open end wrench, and unscrew the valve stem assembly (counter clockwise) from the end fitting. For meters with KYNAR end fittings, when removing the valve stem assembly, the locking tab on the safety lock washer must be bent up away from the nut to permit rotation (see Figure 4-1). (Note: Further disassembly of the valve stem assembly is not required and is not recommended.)

b. Screw the valve stem clockwise into the valve bonnet nut as far as possible to expose the O-ring seal. Using a plastic or wooden toothpick, pry the O-ring from the groove and lightly lubricate it with silicone grease. Replace the O-ring. **DO NOT USE A METAL TOOL TO REMOVE OR REPLACE THE O-RING AS SEVERE DAMAGE MAY RESULT TO THE O-RING GROOVE ON THE VALVE STEM.**

c. Before inserting the valve stem into the end fitting, rotate the valve stem counter clockwise in the valve bonnet nut as far as possible. Then, for stainless steel fittings only, insert the valve stem into the end fitting and tighten the nut while supporting the end fitting with a 7/8 inch open end wrench. **TO ENSURE SAFE OPERATION, TORQUE THE VALVE BONNET NUT TO 100 IN-LBS FOR STAINLESS STEEL END FITTINGS.**

When replacing the valve stem assembly for KYNAR end fittings, place the safety lock washer on the valve end of the fitting with the restraining tab positioned beneath the end fitting as shown in Figure 4-1. Assemble the valve stem into the end fitting as appropriate and torque the valve bonnet nut to 20 in-lbs. If a flat side of the valve bonnet nut does not line up with one of the locking tabs on the lock washer, continue tightening the nut (clockwise) until alignment is attained. Bend down the center locking tab against the appropriate flat on the valve bonnet nut. Should the center locking tab break off, use one of the other two locking tabs and then order spare lock washer(s) (ABB Automation Part No. 377B009U01) to ensure availability for future valve assembly maintenance.

WARNING
NEVER REASSEMBLE THE VALVE ASSEMBLY INTO A KYNAR END FITTING WITHOUT THE SAFETY LOCK WASHER PROPERLY INSTALLED AND THE LOCKING TAB BENT DOWN ON A FLAT OF THE BONNET NUT. THIS IS TO PREVENT INADVERTENT REMOVAL OF THE VALVE STEM ASSEMBLY DURING METER ADJUSTMENT.

d. To complete the assembly, rotate the valve stem clockwise to the desired operating position.

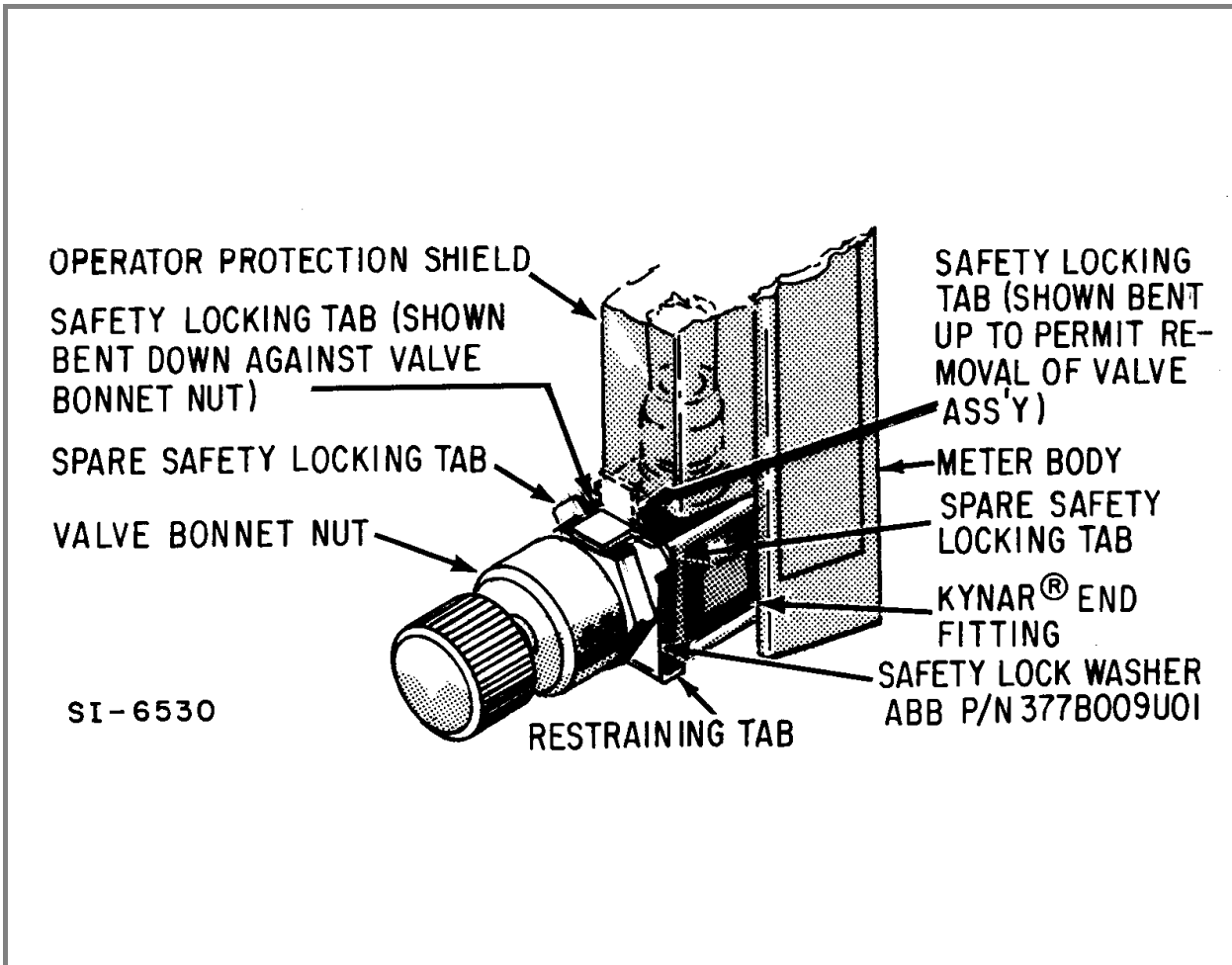

FIGURE 4-1. VALVE STEM ASSEMBLY FOR KYNAR END FITTING

5.0 PARTS LISTS

When ordering parts for the 10A6100 PURGEMASTER Flowmeter, reference the serial number and model number of the meter.

CAUTION

It is important that the meter construction be compatible with the process to which the meter is applied. It is especially important that the O-ring material be compatible with the process fluid. The glass meter tube can break if the improper materials are used.

For example: VITON O-rings must never be used for ammonia service; the corrosive attack of ammonia on VITON is extreme, and could cause a VITON O-ring to swell and break the glass metering tube.

5.1 Basic Meter Parts

Refer to Figure 5-1 and Table 5-1.

INSTRUCTION BULLETIN 10A6100 PURGEMASTER FLOWMETER

TABLE 5-1. BASIC METER PARTS (refer to Figure 5-1)

KEY	PART DESCRIPTION	QTY	END FITTING/ADAPTER MATERIAL AND PART NUMBER			
			316 SST/SST	316 SST/KYNAR	---	KYNAR/KYNAR
1	Body - 1-1/2" scale length - 3" scale length - 5" scale length - 10" scale length	1	355A411U04	355A411U04	---	355A411U04
			355A411U01	355A411U01		355A411U01
			355A411U02	355A411U02		355A411U02
			355A411U03	355A411U03		355A411U03
2	Shield - 1-1/2" scale length - 3" scale length - 5" scale length - 10" scale length	1	351C193U04	351C193U04	---	351C193U04
			351C193U01	351C193U01		351C193U01
			351C193U02	351C193U02		351C193U02
			351C193U03	351C193U03		351C193U03
3	Backing - 1-1/2" scale length - 3" scale length - 5" scale length - 10" scale length	1	331C062U04	331C062U04	---	331C062U04
			331C062U01	331C062U01		331C062U01
			331C062U02	331C062U02		331C062U02
			331C062U03	331C062U03		331C062U03
4	Tube	1	ORDER BY MODEL SERIAL NUMBER			
5	Float	1				
6	Inlet float stop - 1-1/2" scale, 1/16" tube - 1-1/2", 3" scale, 1/8", 5/32" tube - 1-1/2", 3" scale, 1/4" tube - 5", scale, 1/16" tube - 5", 10" scale, 1/8" tube - 5", 10" scale, 1/4" tube	1	---	---	---	---
			304B096U01	304B096U01		304B096U02
			304B071T60	304B071T60		304B071H20
			304B097U02	304B097U02		304B097U01
			304A304U02	304A304U02		304A304U02
			304A303U02	304A303U02		304A303U02
7	Outlet float stop - 1-1/2" scale, 1/16" tube - 1-1/2", 3" scale, 1/8", 5/32" tube - 1-1/2", 3" scale, 1/4" tube - 5", scale, 1/16" tube - 5", 10" scale, 1/8" tube - 5", 10" scale, 1/4" tube	1	304B026T12	304B026T12	---	304B026H20
			304B051T60	304B051T60		304B051H20
			304B014T60	304B014T60		304B014H20
			304B025T12	304B025T12		304B025H20
			304A304U01	304A304U01		304A304U01
			304A303U01	304A303U01		304A303U01
8	End fitting and valve assembly	1	ORDER BY MODEL SERIAL NUMBER			
9	End fitting - no valve - 1/4" NPT - R1/4" - 1/4" BSPT _r	1 or 2	301A346U02	301A346U02	---	301A348U01
			301A346U04	301A346U04		---
			301A346U06	301A346U06		---
10	Retainer	2	390C037V91	390C037V91	---	---
11	Nut	2	---	---	---	397B068U01
12	Safety lock washer	1	---	---	---	377B009U01
13	Adapter - 1/16", 1/8", 5/32" tube - 1/4" tube - 1/16" tube, 5" scale	2	376C160U01	376C163U01	---	376C163U01
			376C161U01	376C162U01		376C162U01
			376C167U01	376C168U01		376C168U01
14	O-ring - Buna-N - VITON	2	101A902U01	101A902U01	---	101A902U01
			101W902U01	101W902U01		101W902U01
15	O-ring - Buna-N - 1/16, 1/8, 5/32" tube - VITON - 1/16, 1/8, 5/32" tube - Buna-N - 1/4" tube - VITON - 1/4" tube - Buna-N - 1/16" tube, 5" scale - VITON - 1/16" tube, 5" scale	2	101A701U01	101A701U01	---	101A701U01
			101W701U01	101W701U01		101W701U01
			101A705U01	101A705U01		101A705U01
			101W705U01	101W705U01		101W705U01
			101A794U01	101A794U01		101A794U01
			101W794U01	101W794U01		101W794U01
16	Gasket - 1/16, 1/8, 5/32" tube - 1/4" tube - 1/16" tube, 5" scale	2	333C469P30	---	---	---
			333C470P30	---		---
			333C246P30	---		---
17	Spring - Retainer	2	376H091U01	376H091U01	---	376H091U01
18	Spring - Adapter	1	424A433U01	424A433U01	---	424A434U01
19	Ball	1	103A073U01	103A073U01	---	103A073U01
20	Spacer	1	301C178U01	301C178U02	---	301C178U02
21	Tag (not shown)	1	338D318U01	338D318U01	---	338D318U01

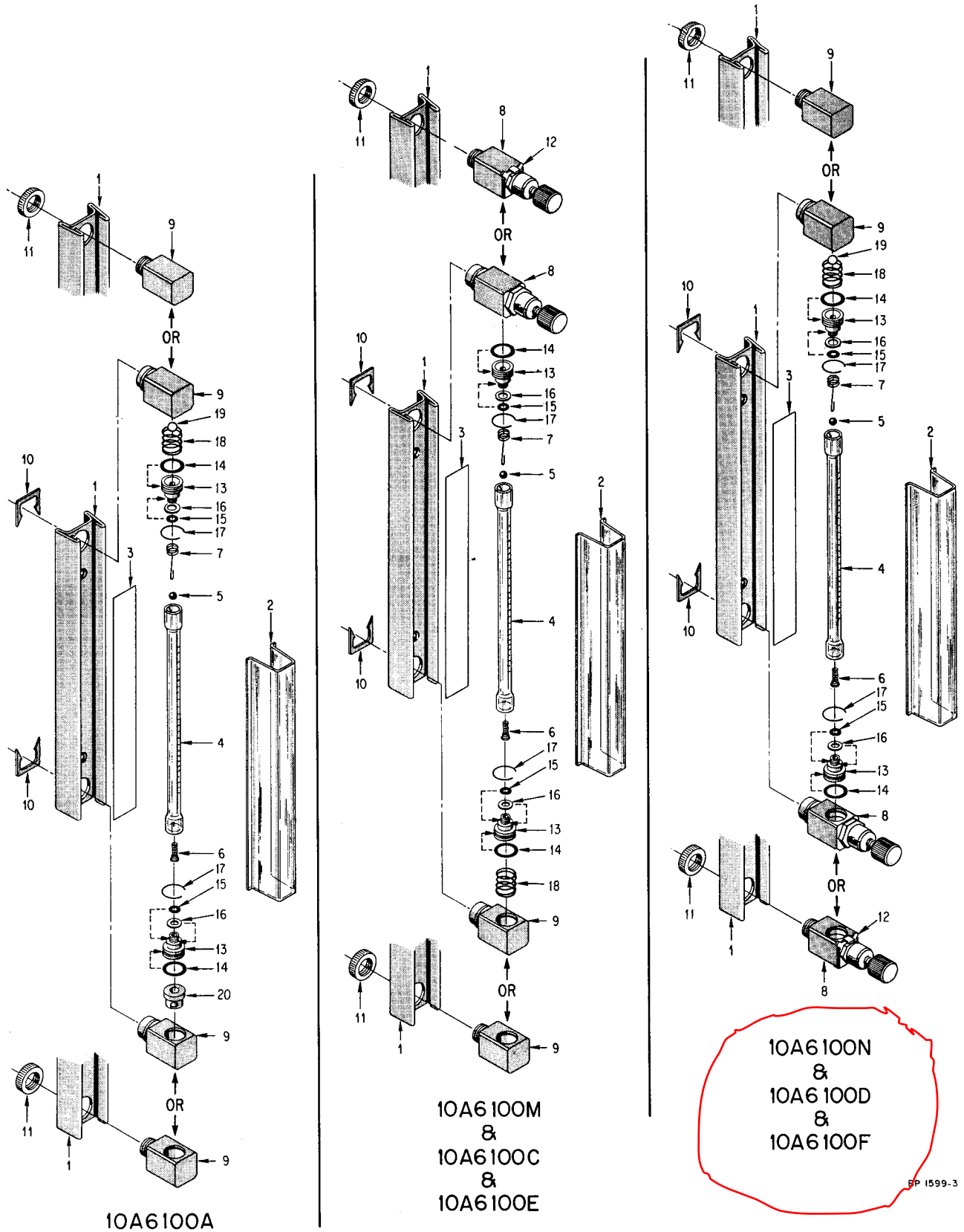

FIGURE 5-1. BASIC METER PARTS

5.2 Alarm Parts

TABLE 5-2. ALARM PARTS (refer to Figure 5-2)

KEY	PART DESCRIPTION	PART NUMBER	QUANTITY
1	Alarm Meter Body - 3" Scale	355A440U01	1
	Alarm Meter Body - 5" Scale	355A440U02	1
	Alarm Meter Body - 10" Scale	355A440U03	1
2	Alarm Shield - 3" Scale	D351C066U03	1
	Alarm Shield - 5" Scale	D351C066U04	1
	Alarm Shield - 10" Scale	D351C066U05	1
3	Screw, 4-40 x 1/4 inch	014F004T10	4
4	Backing - 3" Scale	CD331C002U02	1
	Backing - 5" Scale	CD331C002U03	1
	Backing - 10" Scale	CD331C002U04	1
5	Ring Sensor - 1/8" Tube	L699A064U01	1 or 2
	Ring Sensor - 1/4" Tube	L699A065U01	1 or 2

TABLE 5-3. ALARM SWITCHING AMPLIFIER

ALARM TYPE	POWER SUPPLY	PART NUMBER	QUANTITY
MIN or MAX	110 V ac	163A012U01	1
	220 V ac	163A012U05	1
MIN and MAX	110 V ac	163A012U02	1
	220 V ac	163A012U06	1

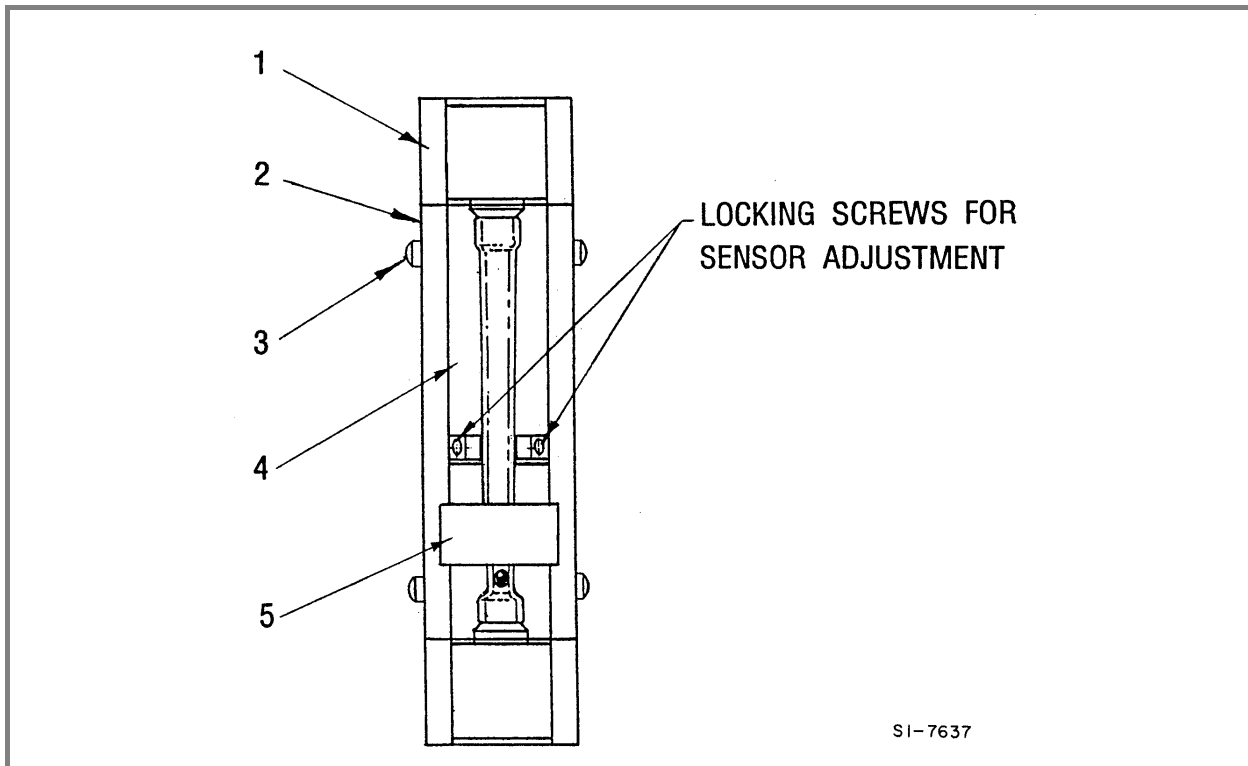

FIGURE 5-2. ALARM PARTS

5.3 Parts For Assembly Of Series 53R-2100 Regulator To Purgemaster Meter (Kit 614B738U01-U12)

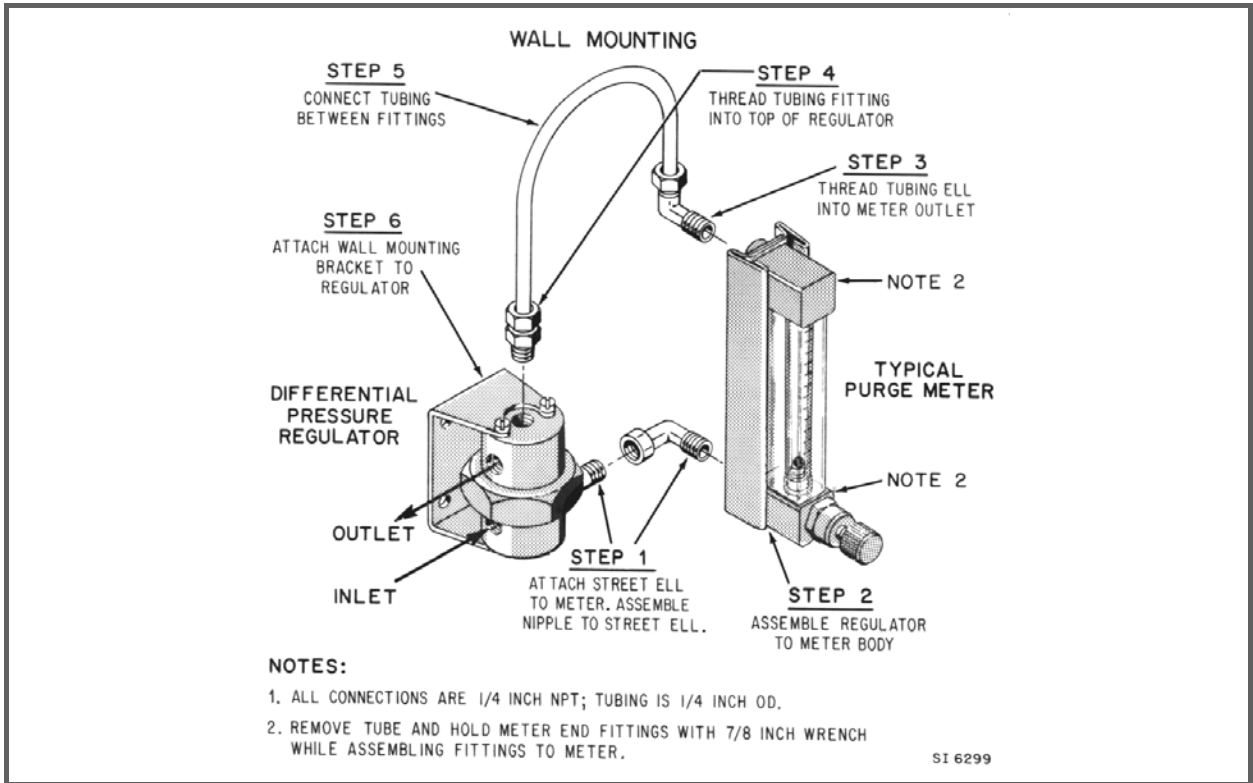

FIGURE 5-3. WALL MOUNTING PROCEDURE

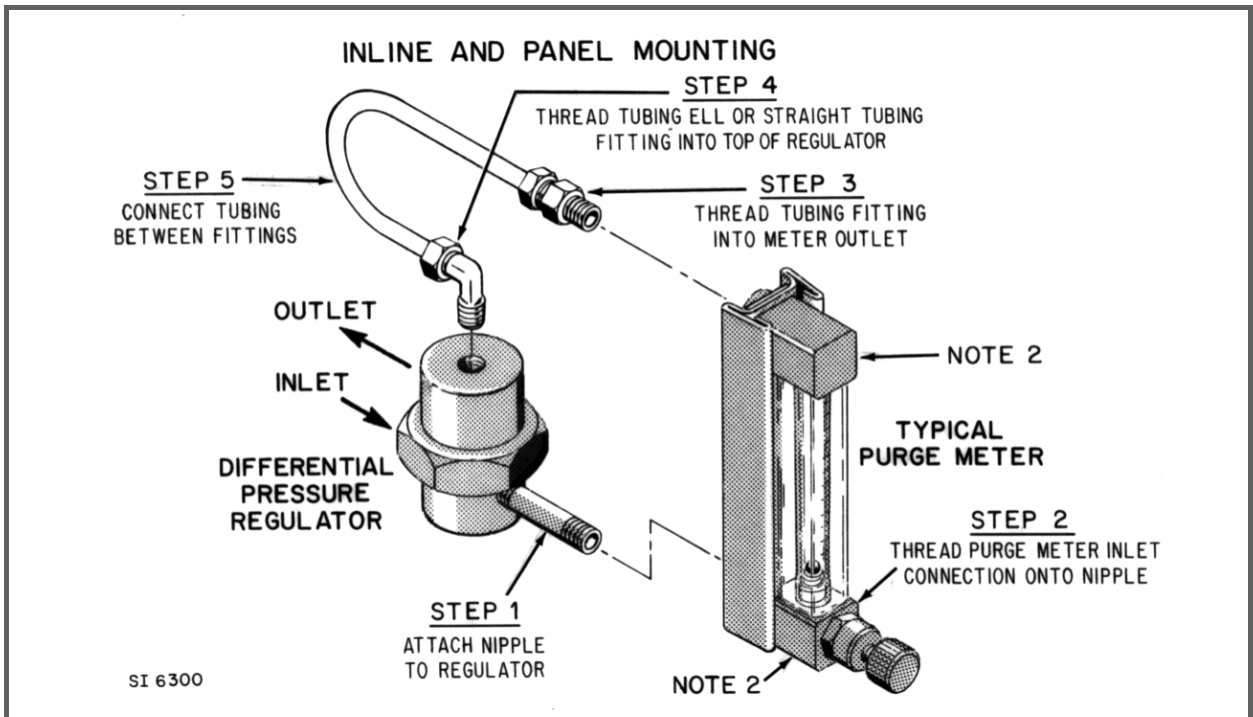

FIGURE 5-4. INLINE & PANEL MOUNTING PROCEDURE

5.3.1 REPLACEMENT PARTS LIST

Refer to Figures 5-3 & 5-4.

TABLE 5-4. BASIC REGULATORS

PART NUMBER	MATERIALS	DESCRIPTION
802C031U01	SS/Viton	Stainless Steel Regulator

TABLE 5-5. BRACKETS & SCREWS FOR WALL-MOUNTING

PART NUMBER	MATERIALS	DESCRIPTION
353B112S11	Steel, painted	Wall Bracket
004L004T10	SS	Screw (10-32 x 1/4) - 4 required per bracket

TABLE 5-6. PIPING KITS FOR IN-LINE OR PANEL-MOUNTED METER UNITS

PART NUMBER	MATERIALS	DESCRIPTION
614B738U03	SS	Piping Kit for 3" Meter
614B738U07	SS	Piping Kit for 5" Meter
614B738U11	SS	Piping Kit for 10" Meter

TABLE 5-7. PIPING KITS FOR WALL-MOUNTED REGULATOR UNITS

PART NUMBER	MATERIALS	DESCRIPTION
614B738U04	SS	Piping Kit for 3" Meter
614B738U08	SS	Piping Kit for 5" Meter
614B738U12	SS	Piping Kit for 10" Meter

5.4 Model 10A6130 Flush Panel Mounting Purgemaster

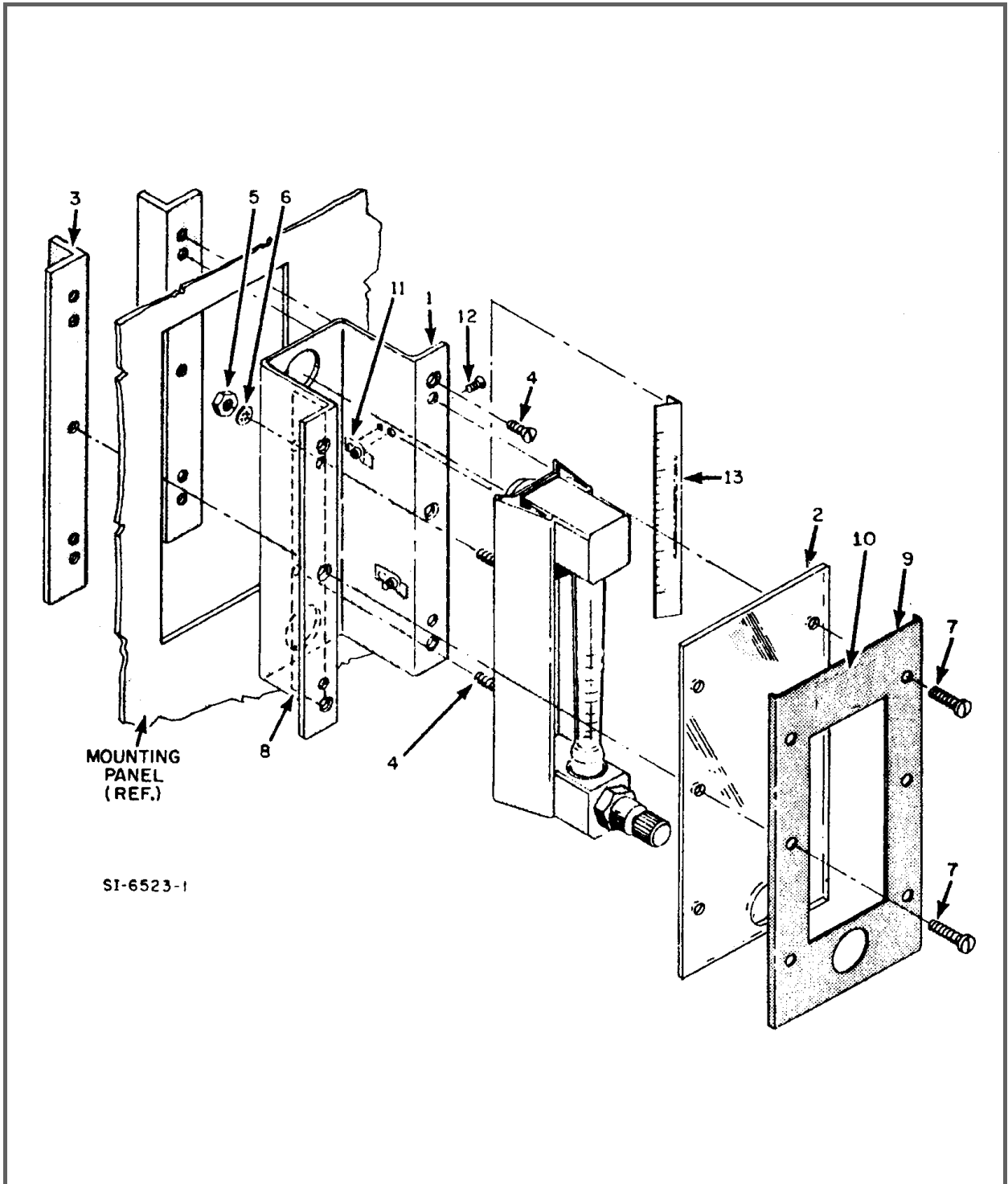

FIGURE 5-5. MODEL 10A6130 FLUSH PANEL MOUNT PARTS

Refer to Table 5-8 for corresponding item-key part numbers.

INSTRUCTION BULLETIN 10A6100 PURGEMASTER FLOWMETER

TABLE 5-8. MODEL 10A6130 FLUSH PANEL MOUNT PARTS LIST

KEY	DESCRIPTION	PART NUMBER							
		1-1/2 INCH		3 INCH		5 INCH		10 INCH	
		Number	Qty	Number	Qty	Number	Qty	Number	Qty
1	BRACKET, METER WITH SCALE ON TUBE BRACKET, METER WITH METAL SCALE	353E369U01 N/A	1	353E369U01 N/A	1	353E369U02 353E369U04	1 1	353E369U03 353E369U05	1 1
2	SHIELD, METER	351C195U07	1	351C195U07	1	351C195U09	1	351C195U11	1
3	BRACKET	353E370U04	2	353E370U01	2	353E370U02	2	353E370U03	2
4	SCREW, FLAT HEAD: #8-32 x 1/2"	002K008T10	4	002K008T10	4	002K008T10	6	002K008T10	6
5	NUT, HEX: #8-32	080K200T10	2	080K200T10	2	080K200T10	2	080K200T10	2
6	WASHER, LOCK: INTERNAL TOOTH #8	085F008V11	2	085F008V11	2	085F008V11	2	085F008V11	2
7	SCREW, PAN HEAD: #8-32 x 5/8"	006K010T10	4	006K010T10	4	006K010T10	6	006K010T10	8
8	TAG	338D318U01	1	338D318U01	1	338D318U01	1	338D318U01	1
9	BEZEL, METER WITH VALVE BEZEL, METER WITHOUT VALVE	330B108U07 330B108U08	1 1	330B108U01 330B108U02	1 1	330B108U03 330B108U04	1 1	330B108U05 330B108U06	1 1
10	MONOGRAM	338A082U02	1	338A082U02	1	338A082U02	1	338A082U02	1
11	CLIP, METAL SCALES	N/A	-	N/A	-	390C101U01	2	390C101U01	2
12	SCREW, FLAT HEAD: #4-40 x 3/16"	N/A	-	N/A	-	002F003T10	2	002F003T10	2
13	SCALE, METAL	N/A	-	N/A	-	*	-	*	-

* Order by specifying ABB serial number

Refer to Figures 2-5 & 2-6 for outline drawings and mounting dimensions.

ABB (www.abb.com) is a leader in power and automation technologies that enable utility and industry customers to improve performance while lowering environmental impact. The ABB Group of companies operates in around 100 countries and employs about 105,000 people.

www.abb.com/instrumentation

The Company's policy is one of continuous product improvement and the right is reserved to modify the information contained herein without notice.

Printed in USA [June, 2005]
© ABB 2005



Germany

**ABB Automation
Products GmbH**
Borsigstr. 2
63755 Alzenau
Tel: +49 (0) 6196 800 0
Fax: +49 (0) 6196 800 1849

UK

ABB Ltd
Oldends Lane, Stonehouse
Gloucestershire GL 10 3TA
Tel: +44 (0) 1453 826 661
FAX: +44 (0) 1453 829 671

Italy

ABB SACE S.p.A
Via Statale 113
20016 Lenno (CO)
Tel: +39 0344 58111
Fax: +39 0344 56278

USA

ABB Inc.
125 East County Line Road
Warminster, PA 18974-4995
Tel: +1 215 674 6000
FAX: +1 215 674 7183

China

ABB (China) Ltd
38th Floor Raffles City (Office Tower)
268 Xizang Zhong Lu
Shanghai 200001
Tel: +86 (0)21 61228888
FAX: +86 (0)21 61228892

PN25104